

Brushless Orbital Sander

Model No:OS-350

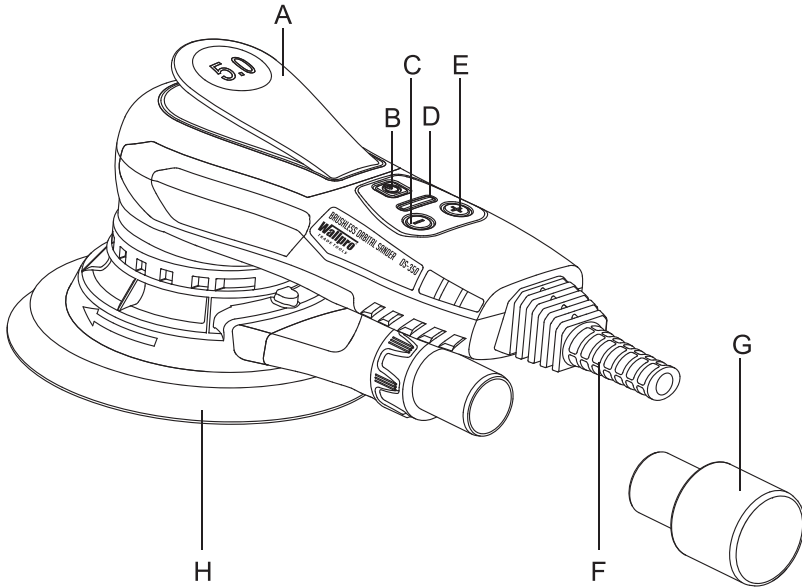

①



A Lever

B On/Off Key

C rpm-

D LED

E rpm+

F Power cord

G Dust hose

H Backing pad

TECHNICAL SPECIFICATIONS

Model Number	OS-350
Voltage	220-240V~,50Hz
Power	350W
No-load Speed	4000-10000 min ⁻¹
Dia. Ø max	150mm
Eccentric	5mm
Protection class	II □

SAFETY

GENERAL SAFETY INSTRUCTIONS



WARNING! Read all safety warnings and all instructions. Failure to follow the warnings and instructions may result in electric shock, fire and/or serious injury. Save all warnings and instructions for future reference. The term “power tool” in the warnings refers to your main operated (corded) power tool or battery-operated (cordless) power tool.

1.WORK AREA SAFETY

- > Keep work area clean and well lit. Cluttered or dark areas invite accidents.
- > Do not operate power tools in explosive atmospheres, such as in the presence of flammable liquids, gases or dust. Power tools create sparks which may ignite the dust or fumes.
- > Keep children and bystanders away while operating a power tool. Distractions can cause you to lose control.

2.ELECTRICAL SAFETY

- > Power tool plugs must match the outlet. Never modify the plug in any way. Do not use any adapter plugs with earthed (grounded) power tools. Unmodified plugs and matching outlets will reduce risk of electric shock.
- > Avoid body contact with earthed or grounded surfaces such as pipes, radiators, ranges and refrigerators. There is an increased risk of electric shock if your body is earthed or grounded.
- > Do not expose power tools to rain or wet conditions. Water entering a power tool will increase the risk of electric shock.
- > Do not abuse the cord. Never use the cord for carrying, pulling or unplugging the power tool. Keep cord away from heat, oil, sharp edges or moving parts. Damaged or entangled cords increase the risk of electric shock.
- > When operating a power tool outdoors, use an extension cord suitable for outdoor use. Use of a cord suitable for outdoor use reduces the risk of electric shock.
- > If operating a power tool in a damp location is unavoidable, use an earth leakage circuit breaker. Use of an earth leakage circuit breaker reduces the risk of electric shock.

3.PERSONAL SAFETY

- > Stay alert, watch what you are doing and use common sense when operating a power tool. Do not use a power tool while you are tired or under the influence of drugs, alcohol or medication. A moment of inattention while operating power tools may result in serious personal injury.

- > Use personal protective equipment. Always wear eye protection. Protective equipment such as dust mask, non-skid safety shoes, hard hat, or hearing protection used for appropriate conditions will reduce personal injuries.
- > Prevent unintentional starting. Ensure the switch is in the off-position before connecting to power source and/or battery pack, picking up or carrying the tool. Carrying power tools with your finger on the switch or energising power tools that have the switch on invites accidents.
- > Remove any adjusting key or wrench before turning the power tool on. A wrench or a key left attached to a rotating part of the power tool may result in personal injury.
- > Do not overreach. Keep proper footing and balance at all times. This enables better control of the power tool in unexpected situations.
- > Dress properly. Do not wear loose clothing or jewelry. Keep your hair, clothing and gloves away from moving parts. Loose clothes, jewelry or long hair can be caught in moving parts.
- > If devices are provided for the connection of dust extraction and collection facilities, ensure these are connected and properly used. Use of dust collection can reduce dust related hazards.

4. POWER TOOL USE AND CARE

- > Do not force the power tool. Use the correct power tool for your application. The correct power tool will do the job better and safer at the rate for which it was designed.
- > Do not use the power tool if the switch does not turn it on and off. Any power tool that cannot be controlled with the switch is dangerous and must be repaired.
- > Disconnect the plug from the power source and/or the battery pack from the power tool before making any adjustments, changing accessories, or storing power tools. Such preventive safety measures reduce the risk of starting the power tool accidentally.
- > Store idle power tools out of the reach of children and do not allow persons unfamiliar with the power tool or these instructions to operate the power tool. Power tools are dangerous in the hands of untrained users.
- > Maintain power tools. Check for misalignment or binding of moving parts, breakage of parts and any other condition that may affect the power tool's operation. If damaged, have the power tool repaired before use. Many accidents are caused by poorly maintained power tools.
- > Keep cutting tools sharp and clean. Properly maintained cutting tools with sharp cutting edges are less likely to bind and are easier to control.

> Use the power tool, accessories and tool bits etc., in accordance with these instructions, taking into account the working conditions and the work to be performed. Use of the power tool for operations different from those intended could result in a hazardous situation.

5. SERVICE

> Have your power tool serviced by a qualified repair person using only identical replacement parts. This will ensure that the safety of the power tool is maintained.

SAFETY INSTRUCTIONS FOR SANDER

1) SAFETY INSTRUCTIONS FOR ALL OPERATIONS

- a) This power tool is intended to function as a sander. Read all safety warnings, instructions, illustrations and specifications provided with this power tool. Failure to follow all instructions listed below may result in electric shock, fire and/or serious injury.
- b) This power tool is not recommended for grinding, wire brushing or cutting off operations. Operations for which the power tool was not designed may create a hazard and cause personal injury.
- c) Do not allow any loose portion of the sanding disc or its attachment strings to spin freely. Tuck away or trim any loose attachment strings. Loose and spinning attachment strings can entangle your fingers or snag on the workpiece.
- d) Do not use accessories which are not specifically designed and recommended by the tool manufacturer. Just because the accessory can be attached to your power tool does not assure safe operation.
- e) The rated speed of the accessory must be at least equal to the maximum speed marked on the power tool. Accessories running faster than their rated speed can fly apart.
- f) The outside diameter and the thickness of your accessory must be within the capacity rating of your power tool. Incorrectly sized accessories cannot be adequately guarded or controlled.
- g) The arbour size of wheels, flanges, backing pads or any other accessory must properly fit the spindle of the power tool. Accessories with arbour holes that do not match the mounting hardware of the power tool will run out of balance, vibrate excessively and may cause loss of control.
- h) Do not use a damaged accessory. Before each use inspect the accessory such as the backing pads for cracks, tears or excess wear. If the power tool or accessory is dropped, inspect for damage or install an undamaged accessory. After inspecting and installing an accessory, position yourself and bystanders away from the plane of the rotating accessory and run the power tool at maximum no load speed for one minute.

- i) Wear personal protective equipment. Depending on application, use face shield, safety goggles or safety glasses. As appropriate, wear dust mask, hearing protectors and gloves capable of stopping small abrasive or workpiece fragments. The eye protection must be capable of stopping flying debris generated by various operations. The dust mask or respirator must be capable of filtering particles generated by your operation. Prolonged exposure to high intensity noise may cause hearing loss.
- j) Keep bystanders a safe distance away from the work area. Anyone entering the work area must wear personal protective equipment. Fragments of the workpiece or of a broken accessory may fly away and cause injury beyond the immediate area of operation.
- k) Position the cord clear of the spinning accessory. If you lose control, the cord may be cut or snagged and your hand or arm may be pulled into the spinning accessory.
- l) Never lay the power tool down until the accessory has come to a complete stop. The spinning accessory may grab the surface and pull the power tool out of your control.
- m) Do not run the power tool while carrying it at your side. Accidental contact with the spinning accessory could snag your clothing, pulling the accessory into your body.
- n) Regularly clean the power tool's air vents. The motor's fan will draw the dust inside the housing and excessive accumulation of powdered metal may cause electrical hazards.
- o) Do not operate the power tool near flammable materials. Sparks could ignite these materials.
- p) Do not use accessories that require liquid coolants. Using water or other liquid coolants may result in electrocution or shock.

2) KICKBACK AND RELATED WARNINGS

- Kickback is a sudden reaction to a pinched or snagged rotating wheel, backing pad, brush or any other accessory. Pinching or snagging causes rapid stalling of the rotating accessory which in turn causes the uncontrolled power tool to be forced in the direction opposite of the accessory's rotation at the point of the binding.

- Kickback is the result of power tool misuse and/or incorrect operating procedures or conditions and can be avoided by taking proper precautions as given below.
- a) Maintain a firm grip on the power tool and position your body and arm to allow you to resist kickback forces. Always use auxiliary handle, if provided, for maximum control over kickback or torque reaction during start-up. The operator can control torque reactions or kickback forces, if proper precautions are taken.
 - b) Never place your hand near the rotating accessory. The accessory may kickback over your hand.
 - c) Do not position your body in the area where power tool will move if kickback occurs. Kickback will propel the tool in the direction opposite to the wheel's movement at the point of snagging.
 - d) Use special care when working corners, sharp edges etc. Avoid bouncing and snagging the accessory. Corners, sharp edges or bouncing have a tendency to snag the rotating accessory and cause loss of control or kickback.

GENERAL

- Only use this tool for dry sanding.
- This tool should not be used by people under the age of 16 years.
- Always disconnect plug from power source before making any adjustment or changing any accessory.
- Do not work materials containing asbestos (asbestos is considered carcinogenic).

ACCESSORIES

- Use only accessories with an allowable speed matching at least the highest no-load speed of the tool.
- Do not use damaged, deformed or vibrating accessories.

OUTDOOR USE

- When used outdoors, connect the tool via a fault current (FI) circuit breaker with a triggering current of 30 mA maximum, and only use an extension cord which is intended for outdoor use and equipped with a splash proof coupling-socket.

BEFORE USE

- Always check that the supply voltage is the same as the voltage indicated on the nameplate of the tool (tools with a rating of 230V or 240V can also be connected to a 220V supply).
- Dust from material such as paint containing lead, some wood species, minerals and metal may be harmful (contact with or inhalation of the dust may cause allergic reactions and/or respiratory diseases to the operator or bystanders); wear a dust mask and work with a dust extraction device when connectible.
- Certain kinds of dust are classified as carcinogenic (such as oak and beech dust) especially in conjunction with additives for wood conditioning; wear a dust mask and work with a dust extraction device when connectible.
- Follow the dust-related national requirements for the materials you want to work with.

AFTER USE

- Before you put down the tool, switch off the motor and ensure that all moving parts have come to a complete standstill.
- After switching off the tool, never stop the rotation of the accessory by a lateral force applied against it.

Proper use of tool

This sander is designed for sanding most types of materials, i.e. metals, wood, stone, plastics, etc. using abrasives designed for this purpose. Do not use this sander for any other purpose than that specified without consulting the manufacturer or the manufacturer's authorised supplier.

Work stations

The tool is intended to be operated as a hand-held tool. It is always recommended that the tool should be used when standing on a solid floor. It can be in any position but before any such use, the operator must be in a secure position, having a firm grip and footing and be aware that the sander can develop a torque reaction. See the section "Operating instructions".

Attaching and changing the sanding paper

Place the sanding paper in the center of the sanding pad and press on. Conduct a test run to check that the sanding disc is clamped in the center.

Replacing the backing pad

Flip the sander over and place on a flat, level surface.

Use the S6 wrench to unscrew the screw in the center of the disc counterclockwise.

Remove the old pad and change to the new one.

Tighten the screw clockwise.

Vacuum pipe installation

Choose one end of the vacuum pipe, connected to the dust outlet of the machine.

Choose another end of the vacuum pipe, connect with 35mm adapter first, then connected with the vacuum cleaner.

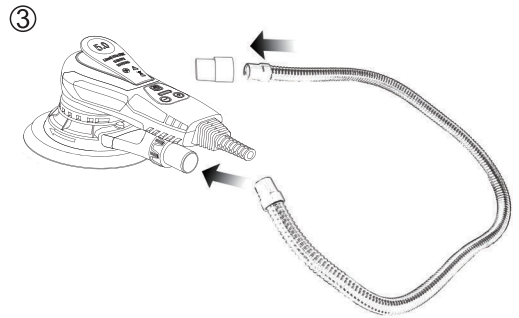
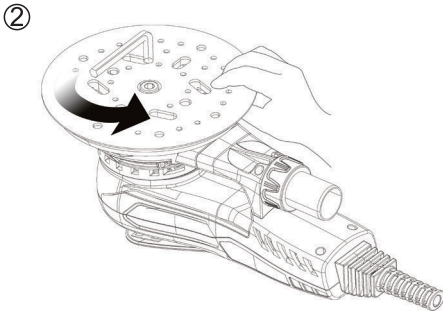

Operating instructions

The tool is intended to be operated as a hand held tool. The tool can be used in any position. Note: The sander can develop a torque reaction when started.

Make sure the sander is switched off. Select a suitable abrasive and secure it to the backing pad. Make sure the abrasive is centered on the backing pad.

Switch on the sander by pressing the On/Off key, Figure 1. The sander LED is now green.

The sander can now be started by pressing the lever.

The speed can be adjusted between 4,000rpm and max rpm by adjusting the position of the lever.

The max rpm can be adjusted by pressing rpm+ or rpm–, Figure 1. Each press increases or reduces the speed by 1,200rpm until it reaches the limit. The rpm can be adjusted in the range of 4,000 to 10,000 rpm.

The tool has two speed control modes. In the default mode the speed can be adjusted linearly by changing the position of the lever. In the other mode the speed remains fixed at the set max rpm when the tool is running. When the rpm+ and rpm– buttons are pressed simultaneously the tool toggles between the two controlling modes.

When sanding, always place the tool on the work surface before starting the tool. Always remove the tool from the work surface before stopping it. This will prevent gouging of the work surface due to excess speed of the abrasive.

When sanding is finished, turn off the sander by pressing the On/Off key. The sander LED is now turned off.

Troubleshooting guide

Symptom	Possible cause	Solution
The sander LED shows normal, the rpm- and rpm+ keys are normal, but the switch does not work.	Damaged Hall components.	Send machine back to after sales service, changing hall components.
After plugging in, no matter what button is pressed, the LED light will not light up.	Switch damaged.	Change switch components.
The LED light does not light up and the machine stops working.	Input voltage is lower than 170VAC +10VAC, the machine enters low voltage protection.	Change to the right input voltage, above 180V and below 285V.
The LED1, LED3, LED5 light up, Other lights off.	Input voltage is lower than 275VAC +10VAC, the machine enters high voltage protection.	Change to the right input voltage, above 180V and below 285V.
The LED1, LED6 light up, other lights off.	The three wires of the motor are loose or broken.	Send machine back to after sales service for repair.

MAINTENANCE

Protect the tool from impact, shock and grease.

Always keep tool and cord clean (especially ventilation slots).

Disconnect the plug before cleaning.

Do not attempt to clean ventilation slots by inserting pointed objects through openings.

ENVIRONMENT



Do not dispose of electric tools, accessories and packaging together with household waste material.



WARRANTY

Wallboard Tool Co Pty Ltd warrants that this product will be free from any defect in materials or workmanship for twelve (12) months from your Purchase Date (noted on your invoice or receipt). At its discretion, Wallboard Tool Co Pty Ltd will either repair or replace your product, if it is found on inspection by Wallboard Tool Co Pty Ltd or a registered and approved Wallpro Service Agent to have any such defect.

WARRANTY CLAIM PROCEDURE

To make a claim under this Warranty, you must:

- First contact the Wallboard Tool Co Pty Ltd distributor where you purchased the product.
- Return the product to the distributor accompanied by the proof of purchase (invoice or receipt).

You will be responsible for the delivery to and collection of the product from the distributor.

WARRANTY APPLICATION

This Warranty applies only:

- To a product sold to you by Wallboard Tool Co Pty Ltd or by a Wallboard Tool Co Pty Ltd distributor.
- If you use the product for your private or business purposes.

WARRANTY EXCLUSIONS

This Warranty will not apply if any of the following occurs during the relevant warranty period:

- The product is serviced or repaired by anyone other than by a registered and approved Wallpro service agent.
- You use a Product contrary to the technical or operating environment guidelines recommended in its user guide or manual;
- Any wear parts included in your product, (for example: including but without limitation: Velcro Foam Adaptors, Bearings, etc), reaches the end of its service life;
- A product's malfunction or failure to perform to Wallboard Tool Co Pty Ltd specifications results from;
 1. deliberate or accidental damage; or
 2. neglect or modification; or
 3. incorrect voltage or a power surge; or
 4. use of non-genuine replacement parts or accessories.

DETAILS OF THE COMPANY GIVING THIS WARRANTY:

Wallboard Tool Co Pty Ltd

30 Leda Drive, West Burleigh, Qld 4220, Australia

Phone: +61 7 5535 7655

Email: cs@wbtco.com.au

The Wallboard Tools and Wallpro names as well as the Wallboard Tools and Wallpro Trade Tools logos are registered Trade Marks of Wallboard Tool Co Pty Ltd.

On the product, the rating label and within these instructions you will find among others the following symbols and abbreviations. Familiarise yourself with them to reduce hazards like personal injuries and damage to property.

V~	Volt, (alternating voltage)	mm	Millimetre
Hz	Hertz	kg	Kilogram
W	Watt	dB(A)	Decibel (A-rated)
/min or min ⁻¹	Per minute	m/s ²	Metres per seconds squared



Lock / to tighten or secure.



Unlock / to loosen.



Note / Remark.



Caution / Warning.



Read the instruction manual.



Wear hearing protection.



Wear eye protection.



Wear a dust mask.



Wear protective gloves.



Wear protective, slip-resistant footwear.



Switch the product off and disconnect it from the power supply before assembly, cleaning, adjustments, maintenance, storage and transportation.



This product is of protection class II. That means it is equipped with enhanced or double insulation.



The product complies with the applicable European directives and an evaluation method of conformity for these directives was done.



WEEE symbol. Waste electrical products should not be disposed of with household waste. Please recycle where facilities exist. Check with your Local Authority or local store for recycling advice.

